

RLP Roller Pallet Loading Conveyors

The RLP family of gravity roller conveyors are used at the beginning or end of gravity or powered lines for loading or removing pallets or large boxes. The end part of the conveyor is fork-like to enable a hand-pallet to enter the loading area to deposit or remove pallets. They are virtually maintenance-free and are manually operated thus require no energy.

Factory :New Borg El Arab 2nd Zone
entrance 2c street 3 - entrance 2c street 5
Tel:+20-(03)-4624127 - 4624126 - 4624025
fax : (03) 4624291

Info@UnitelEgypt.com

Cairo Office : Corniche El Nile, Maadi, Cairo
Tel +20:(0)2-25266333
Fax +20:(0)2-25264888

Sales@UnitelEgypt.com



www.UnitelEgypt.com



[/UnitelEgypt](https://www.facebook.com/UnitelEgypt)

RLP Roller Pallet Loading Conveyors

Features

RLP Roller Gravity Conveyors are heavy duty conveyors that offer cost effective, safe and virtually maintenance-free handling of pallets or similar items with suitable contact surface.

The end part is a fork-like structure which enables hand pallets to move into the loading area and deposit or remove pallets.

In case of removal, a mechanical spring operated interlocking system prevents incoming pallets from accumulating behind the pallet being removed. Once a pallet is removed, the interlock allows the next pallet to be fed into the unloading station..

Characteristics

The RLP family of conveyors uses R50, R60 or R89 rollers ..

The heavy duty precision side frames are made of heavy gauge precision punched sheet metal.

The safety interlocking mechanism is spring operated and requires no energy.

Applications

These heavy duty conveyors are used for feeding or unloading unit goods such as pallets, boxes, cartons, unit loads with a flat contact surface in warehouses and production lines.

They can be used as stand-alone conveyors in warehousing systems, or production lines, or in conjunction with RDS live roller conveyors and CHT chain conveyors.

RLP Roller Pallet Loading Conveyors

Specifications

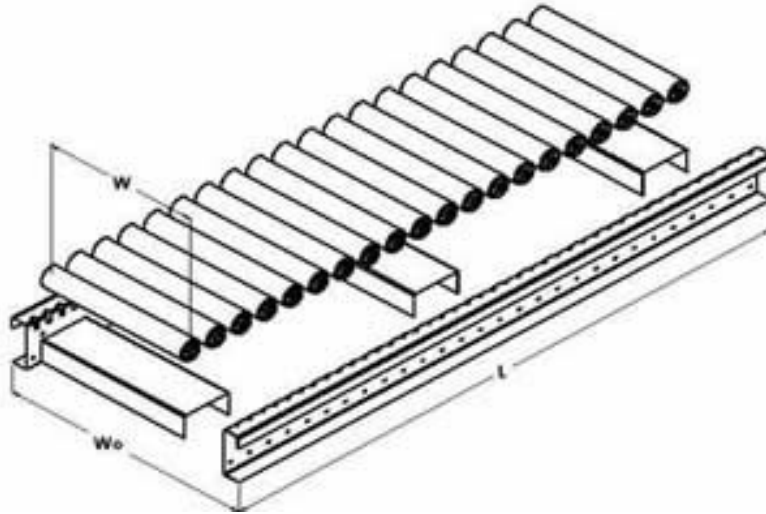

Loading Capacity	14,000 N/m
Roller Diameter	50, 60 or 89 mm.
Roller Pitch	120 mm.
Linear Speed	Max 15 m/min.
Paint	Electrostatic Epoxy Powder RAL 5017 (Blue)

Dimensions

Standard Width (W) / Preferred Values

Outer Distance (Wo)

W	1000	1100	1200
Wo	1100	1200	1300

Standard Section Length / Preferred Values

Combine Standard Length	1242	2400
--------------------------------	-------------	-------------

RLP Roller Pallet Loading Conveyors

Accessories

Accessories	
Under-Trussing	No
Cross Bracing	Yes
Butt Coupling	Yes
End Stops	Yes
Guard Rails	Yes
Push Button Station	Yes
Optical Switches and Controls	Yes

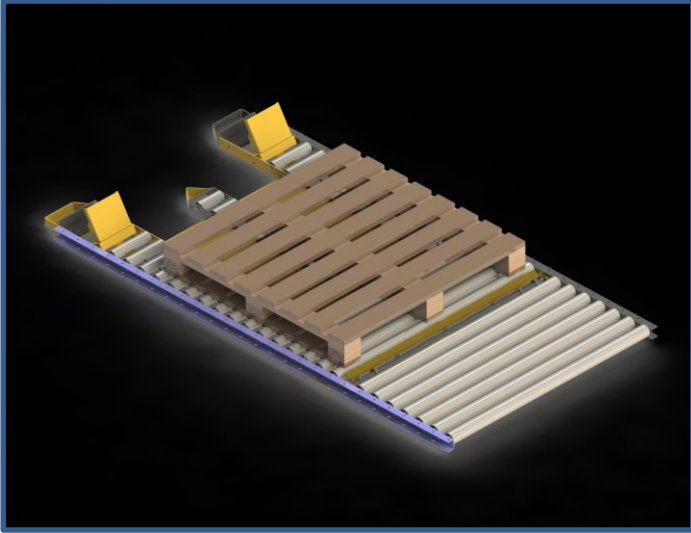

مكتب القاهرة : برج القانوينين كورنيش المعادى
تليفون : ٢/٢٥٢٦٦٣٣٣
فاكس : ٢/٢٥٢٦٤٨٨٨

مدينة برج العرب الجديدة - المنطقة الصناعية الثانية
يونيتل/ مدخل ٢ ج شارع ٣ - مدخل ٢ ج شارع ٥
تليفون : ٣/٤٦٢٤٤٢٤-٤٦٢٤٠٢٥-٤٦٢٤١٢٦-٤٦٢٤١٢٧
فاكس : ٣/٤٦٢٤٢٩١



www.UnitelEgypt.com



/UnitelEgypt

Sales@UnitelEgypt.com

Info@UnitelEgypt.com